

# MTP 15HD A Series

High Resolution Video and Serial Link  
MTP Transmitters and Receivers



**Extron® Electronics**  
INTERFACING, SWITCHING AND CONTROL

# Safety Instructions

## Safety Instructions • English

**WARNING:** This symbol, ⚠, when used on the product, is intended to alert the user of the presence of uninsulated dangerous voltage within the product's enclosure that may present a risk of electric shock.

**ATTENTION:** This symbol, ⚠, when used on the product, is intended to alert the user of important operating and maintenance (servicing) instructions in the literature provided with the equipment.

For information on safety guidelines, regulatory compliances, EMI/EMF compatibility, accessibility, and related topics, see the Extron Safety and Regulatory Compliance Guide, part number 68-290-01, on the Extron website, [www.extron.com](http://www.extron.com).

## Instructions de sécurité • Français

**AVERTISSEMENT:** Ce pictogramme, ⚠, lorsqu'il est utilisé sur le produit, signale à l'utilisateur la présence à l'intérieur du boîtier du produit d'une tension électrique dangereuse susceptible de provoquer un choc électrique.

**ATTENTION:** Ce pictogramme, ⚠, lorsqu'il est utilisé sur le produit, signale à l'utilisateur des instructions d'utilisation ou de maintenance importantes qui se trouvent dans la documentation fournie avec le matériel.

Pour en savoir plus sur les règles de sécurité, la conformité à la réglementation, la compatibilité EMI/EMF, l'accessibilité, et autres sujets connexes, lisez les informations de sécurité et de conformité Extron, réf. 68-290-01, sur le site Extron, [www.extron.fr](http://www.extron.fr).

## Sicherheitsanweisungen • Deutsch

**WARNUNG:** Dieses Symbol ⚠ auf dem Produkt soll den Benutzer darauf aufmerksam machen, dass im Inneren des Gehäuses dieses Produktes gefährliche Spannungen herrschen, die nicht isoliert sind und die einen elektrischen Schlag verursachen können.

**VORSICHT:** Dieses Symbol ⚠ auf dem Produkt soll dem Benutzer in der im Lieferumfang enthaltenen Dokumentation besonders wichtige Hinweise zur Bedienung und Wartung (Instandhaltung) geben.

Weitere Informationen über die Sicherheitsrichtlinien, Produkthandhabung, EMI/EMF-Kompatibilität, Zugänglichkeit und verwandte Themen finden Sie in den Extron-Richtlinien für Sicherheit und Handhabung (Artikelnummer 68-290-01) auf der Extron-Website, [www.extron.de](http://www.extron.de).

## Instrucciones de seguridad • Español

**ADVERTENCIA:** Este símbolo, ⚠, cuando se utiliza en el producto, avisa al usuario de la presencia de voltaje peligroso sin aislar dentro del producto, lo que puede representar un riesgo de descarga eléctrica.

**ATENCIÓN:** Este símbolo, ⚠, cuando se utiliza en el producto, avisa al usuario de la presencia de importantes instrucciones de uso y mantenimiento recogidas en la documentación proporcionada con el equipo.

Para obtener información sobre directrices de seguridad, cumplimiento de normativas, compatibilidad electromagnética, accesibilidad y temas relacionados, consulte la Guía de cumplimiento de normativas y seguridad de Extron, referencia 68-290-01, en el sitio Web de Extron, [www.extron.es](http://www.extron.es).

## Chinese Simplified (简体中文)

**警告:** ⚠ 产品上的这个标志意在警告用户该产品机壳内有暴露的危险电压,有触电危险。

**注意:** ⚠ 产品上的这个标志意在提示用户设备随附的用户手册中有重要的操作和维护(维修)说明。

关于我们产品的安全指南、遵循的规范、EMI/EMF 的兼容性、无障碍使用的特性等相关内容, 敬请访问 Extron 网站 [www.extron.cn](http://www.extron.cn), 参见 Extron 安全规范指南, 产品编号 68-290-01。

## Chinese Traditional (繁體中文)

**警告:** ⚠ 若產品上使用此符號, 是為了提醒使用者, 產品機殼內存在著可能會導致觸電之風險的未絕緣危險電壓。

**注意:** ⚠ 若產品上使用此符號, 是為了提醒使用者。

有關安全性指導方針、法規遵守、EMI/EMF 相容性、存取範圍和相關主題的詳細資訊, 請瀏覽 Extron 網站: [www.extron.cn](http://www.extron.cn), 然後參閱《Extron 安全性與法規遵守手冊》, 準則編號 68-290-01。

## Japanese

**警告:** この記号 ⚠ が製品上に表示されている場合は、筐体内に絶緣されていない高電圧が流れ、感電の危険があることを示しています。

**注意:** この記号 ⚠ が製品上に表示されている場合は、本機の取扱説明書に記載されている重要な操作と保守(整備)の指示についてユーザーの注意を喚起するものです。

安全上のご注意、法規遵守、EMI/EMF適合性、その他の関連項目については、エクストロンのウェブサイト[www.extron.jp](http://www.extron.jp)より『Extron Safety and Regulatory Compliance Guide』(P/N 68-290-01)をご覧ください。

## Korean

**경고:** 이 기호 ⚠, 가 제품에 사용될 경우, 제품의 인클로저 내에 있는 접지되지 않은 위험한 전류로 인해 사용자가 감전될 위험이 있음을 경고합니다.

**주의:** 이 기호 ⚠, 가 제품에 사용될 경우, 장비와 함께 제공된 책자에 나와 있는 주요 운영 및 유지보수(정비) 지침을 경고합니다.

안전 가이드라인, 규제 준수, EMI/EMF 호환성, 접근성, 그리고 관련 항목에 대한 자세한 내용은 Extron 웹 사이트([www.extron.co.kr](http://www.extron.co.kr))의 Extron 안전 및 규제 준수 안내서, 68-290-01 조항을 참조하십시오.

## FCC Class A Notice

This equipment has been tested and found to comply with the limits for a Class A digital device, pursuant to part 15 of the FCC rules. The Class A limits provide reasonable protection against harmful interference when the equipment is operated in a commercial environment. This equipment generates, uses, and can radiate radio frequency energy and, if not installed and used in accordance with the instruction manual, may cause harmful interference to radio communications. Operation of this equipment in a residential area is likely to cause interference; the user must correct the interference at his own expense.

**NOTE:** This unit was tested with shielded I/O cables on the peripheral devices. Shielded cables must be used to ensure compliance with FCC emissions limits. For more information on safety guidelines, regulatory compliances, EMI/EMF compatibility, accessibility, and related topics, see the “**Extron Safety and Regulatory Compliance Guide**” on the Extron website.

### Copyright

© 2013 Extron Electronics. All rights reserved.

### Trademarks

All trademarks mentioned in this guide are the properties of their respective owners.

**The following registered trademarks<sup>(R)</sup>, registered service marks<sup>(SM)</sup>, and trademarks<sup>(TM)</sup> are the property of RGB Systems, Inc. or Extron Electronics:**

Registered Trademarks <sup>(®)</sup>
AVTrac, Cable Cubby, CrossPoint, eBUS, EDID Manager, EDID Minder, Extron, Flat Field, GlobalViewer, Hideaway, Inline, IP Intercom, IP Link, Key Minder, LockIt, MediaLink, PoleVault, PowerCage, PURE3, Quantum, SoundField, System Integrator, TouchLink, V-Lock, VersaTools, VN-Matrix, VoiceLift, WallVault, WindowWall
<b>Registered Service Mark<sup>(SM)</sup> :</b> S3 Service Support Solutions
Trademarks <sup>(TM)</sup>
AAP, AFL (Accu-Rate Frame Lock), ADSP (Advanced Digital Sync Processing), AIS (Advanced Instruction Set), Auto-Image, CDRS (Class D Ripple Suppression), DDSP (Digital Display Sync Processing), DMI (Dynamic Motion Interpolation), Driver Configurator, DSP Configurator, DSVP (Digital Sync Validation Processing), FastBite, FOXBOX, IP Intercom HelpDesk, MAAP, MicroDigital, ProDSP, QS-FPC (QuickSwitch Front Panel Controller), Scope-Trigger, SIS, Simple Instruction Set, Skew-Free, SpeedMount, SpeedNav, SpeedSwitch, Triple-Action Switching, XTP, XTP Systems, XTRA, ZipCaddy, ZipClip

---

## Conventions Used in this Guide

### Notifications

The following notifications are used in this guide:

**WARNING:** A warning indicates a situation that has the **potential** to result in death or severe injury.

**ATTENTION:** Attention indicates a situation that may damage or destroy the product or associated equipment.

**NOTE:** A note draws attention to important information.

### Specifications Availability

Product specifications are available on the Extron website, [www.extron.com](http://www.extron.com).

# Contents

---

## **Introduction ..... 1**

About this Guide.....	1
About the MTP Transmitters and Receivers .....	2
Twisted Pair Cable Advantages.....	2
Transmission Distance .....	3

---

## **Installation and Operation ..... 5**

Installation Overview .....	5
Front Panel Features.....	6
Transmitter Rear Panel Features .....	9
Receiver Rear Panel Features .....	11
Power Supply Wiring and Grounding .....	12
Twisted Pair Cable Termination .....	14
Skew Delay Compensation.....	15
SEQ Receiver Skew Compensation.....	15
Non-SEQ Receiver Skew Compensation ...	15
EDID Configuration .....	16
Recording a Display EDID.....	16
Using a Pre-Programmed or User-Recorded EDID .....	16

---

## **Reference Information ..... 17**

Part Numbers, Optional Accessories, Cables, and Connectors.....	17
Part Numbers .....	17
Optional Accessories .....	17
Cables.....	18
Connectors.....	18

---

## **Mounting..... 19**

Tabletop Placement.....	19
Under Desk and Furniture Mounting .....	19
Rack Mounting .....	19
UL Guidelines for Rack Mounting.....	19
Rack Mounting Procedure .....	20
Back of the Rack Mounting Procedure .....	20
Projector Mounting .....	20

# Introduction

This section gives an overview of the user guide. This section also describes the MTP 15HD A Series of transmitters and receivers. Covered topics are:

- **About this Guide**
- **About the MTP Transmitters and Receivers**
- **Transmission Distance**

## About this Guide

This guide contains installation, configuration, and operation information for two families of Extron MTP transmitters and receivers.

- **MTP products** that are compatible with:
  - Extron Enhanced Skew-Free™ AV UTP cable
  - Category (CAT) 5, 5e, and 6 shielded twisted pair (STP), unshielded twisted pair (UTP), or foil shielded twisted pair (FTP) cable.
- **MTP C7 [CAT 7, C7]** products that are compatible with Shielded Twisted Pair 201 (STP201) or CAT 7 cable **only**.

In this guide, any reference to these products refers to either family, unless explicitly stated.

**NOTE:** For clarity and where applicable, in this guide, the CAT 5, 5e, 6 versions are referred to as non-C7 MTPs.

This guide details the installation and operation of the following products:

- MTP T 15HD A twisted pair (TP) transmitter
- MTP RL 15HD A receiver with loop-through
- MTP RL 15HD A SEQ receiver with loop-through and skew equalization

In this guide:

- The term "transmitter" refers specifically to the MTP T 15HD A transmitter.
- The term "receiver" refers to either of the receiver models — the MTP RL 15HD A or MTP RL 15HD A SEQ.
- The term "SEQ receiver" refers specifically to the MTP RL 15HD A SEQ receiver with skew equalization capabilities.

## About the MTP Transmitters and Receivers

The Extron MTP T 15HD A transmitter and MTP RL 15HD A and MTP RL 15HD A SEQ receivers are a system for long-distance distribution of VGA or other high resolution video and audio.

The MTPs are a part of the Extron compact line of basic distribution amplifiers, switchers, transmitters and receivers, and associated video accessories.

High resolution video on a 15-pin HD connector as well as stereo audio on a 3.5 mm stereo jack is sent to the MTP transmitter. The transmitter sums the left and right audio channels to convert the audio to mono (L+R) format. The MTP T then converts the input video and mono audio signals to proprietary signals and outputs them to the compatible MTP receiver on an RJ-45 connector. A pre-peaking control allows you to boost the transmission distance of the proprietary signal. The transmitter also makes the input video available for local use on a 15-pin HD connector.

The transmitted proprietary signal is sent to the receiver on an RJ-45 connector and converts the signal back into its high resolution video and mono audio components. The receiver outputs the video on a 15-pin HD connector and the two sets of identical mono audio signals on a single 3.5 mm captive screw connector (A series only; RS series outputs on a RS-232 connection).

The receiver also buffers the proprietary input signal and sends it to another compatible MTP receiver or to a daisy chain of receivers.

### NOTES:

- The transmitter provides pre-peaking, which boosts the signal before it is transmitted. The buffered output on the receiver does not provide any pre-peaking control. The total recommended distance (see the [table](#) on page 4) for an entire daisy chain is the same as for a single transmitter and receiver. The Pre-Peak switch on the transmitter has the same effect on the recommended transmission distance for a daisy chain as for a single transmitter and receiver.
- Up to eight receivers can be connected in series using Buffered Output connectors, provided that the total distance from the twisted pair output of the transmitter to the last receiver in the chain does not exceed the recommended distance for the resolution being used.

The SEQ receiver also corrects the skew delay commonly encountered when CAT 5, 5e, 6, 7, or STP201 cables are used for RGB video, component video, and S-video transmission.

**NOTE:** An SEQ receiver should not be necessary when Extron Enhanced Skew-Free AV UTP cable and non-C7 transmitters and receivers are used.

Each MTP transmitter and receiver model is shipped with an external desktop 12 V power supply that accepts 100 VAC to 240 VAC, 50-60 Hz input.

## Twisted Pair Cable Advantages

Twisted pair cable is smaller, lighter, more flexible, and less expensive than coaxial cable. Termination of the cable with RJ-45 connectors is simple, quick, and economical.

## Transmission Distance

The maximum distance is determined by the frequency and resolution of the signal that is input to the transmitter. The **table** on page 4 specifies the recommended maximum transmission distances and transmitter Pre-Peak switch positions (see figure 3, ⑤ on page 9) using Extron Enhanced Skew-Free AV UTP cable, STP201 cable, or CAT 5, 5e, 6, or 7 cable, terminated with RJ-45 connectors.

### NOTES:

- The transmitter and receiver are designed for and perform best with Extron Enhanced Skew-Free AV UTP cable terminated in accordance with the TIA/EIA T 568 A wiring standard. CAT 5, 5e, and 6 cables are acceptable, but less preferable. We also recommend the use of pre-terminated and tested cables. Cables terminated on site should be tested before use to ensure that they comply with Category 5 specifications.
- The recommendations shown in the **table** on page 4 apply for a single transmitter and receiver and for a daisy chain. For example, the maximum suggested range for 1024 x 768 video is 300 feet (90 m) with the Pre-Peak switch off and 500 feet (150 m) with the Pre-Peak switch on, whether the system consists of one transmitter and one receiver or a transmitter and three daisy-chained receivers.
- Extron recommends using at least 25 feet of twisted pair cable between the transmitter and the first receiver.
- For daisy-chained units, the first receiver in the chain must be at least 100 feet (30 m) from the transmitter when the Pre-Peak switch is on.
- For daisy-chained units, any receiver in the chain closer than 350 feet (105 m) may experience some form of over-peaking when the Pre-Peak switch is on. An over-peaked image may appear bloomed.



<b>Video Format</b>	<b>Pre-Peak off</b>	<b>Pre-Peak on</b>	<b>Max. distance (high quality)</b>	<b>Max. distance (variable quality)</b>
Composite, S-video, Component			800' (245 m)	1000' (300 m)
640 x 480	<300' (90 m)	>350' (105 m)	700' (215 m)	750' (240 m)
800 x 600	<300' (90 m)	>350' (105 m)	550' (165 m)	650' (200 m)
1024 x 768*	<300' (90 m)	>350' (105 m)	500' (150 m)	600' (185 m)
1280 x 960*	<300' (90 m)	>350' (105 m)	400' (120 m)	500' (150 m)
1280 x 1024*	<250' (75 m)	>300' (90 m)	350' (105 m)	450' (135 m)
1360 x 765	<250' (75 m)	>300' (90 m)	400' (120 m)	500' (150 m)
1365 x 768	<250' (75 m)	>300' (90 m)	400' (120 m)	450' (135 m)
1366 x 768	<250' (75 m)	>300' (90 m)	400' (120 m)	450' (135 m)
1400 x 1050	<250' (75 m)	>300' (90 m)	350' (105 m)	400' (120 m)
1440 x 900	<250' (75 m)	>300' (90 m)	350' (105 m)	400' (120 m)
1600 x 1200*	<250' (75 m)	>300' (90 m)	300' (90 m)	450' (135 m)
1920 x 1200	<250' (75 m)	>300' (90 m)	300' (90 m)	400' (120 m)
2048 x 1080	<250' (75 m)	>300' (90 m)	300' (90 m)	400' (120 m)
HDTV 720p	<250' (75 m)	>300' (90 m)	400' (120 m)	500' (150 m)
HDTV 1080i	<250' (75 m)	>300' (90 m)	300' (90 m)	400' (120 m)
HDTV 1080p	<250' (75 m)	>300' (90 m)	300' (90 m)	400' (120 m)

**Figure 1. Recommended Pre-Peak Switch Positions and Transmission Distances at 60 Hz**

**NOTES:**

- Resolutions marked with an asterisk (\*) in the table above have the same range specifications at 75 Hz.
- It is possible to exceed the recommended distance; however, image quality may be reduced.

# Installation and Operation

This section provides information on:

- [Installation Overview](#)
- [Front Panel Features](#)
- [Transmitter Rear Panel Features](#)
- [Receiver Rear Panel Features](#)
- [Power Supply Wiring and Grounding](#)
- [Twisted Pair Cable Termination](#)
- [Skew Delay Compensation](#)
- [EDID Configuration](#)

## Installation Overview

Follow the steps below to properly install and operate any of the Extron MTP 15HD A transmitters and receivers.

**ATTENTION: Potential damage to property.**

Do not connect these devices to a computer data or telecommunications network.

1. Turn off all MTPs and devices. Make sure that the input sources, the MTP, and the output sources are all turned off and all power sources and signal cables are disconnected.
2. Connect the transmitter inputs (see [Transmitter Rear Panel Features](#) on page 9).
3. Connect twisted pair (TP) cables between the MTP units (see [Transmitter Rear Panel Features](#) on page 9 and [Receiver Rear Panel Features](#) on page 11).
4. Connect the receiver outputs (see [Receiver Rear Panel Features](#) on page 11).
5. Configure the receiver DIP switches (see [Receiver Rear Panel Features](#) on page 11).
6. Configure the EDID (see [Front Panel Features](#) on page 6 and [EDID Configuration](#) on page 16).
7. Connect the power supply and turn on all devices (see [Power Supply Wiring](#) on page 12).
8. Adjust the level and peaking (see [Front Panel Features](#) on page 6).
9. Adjust the skew delay control (see [Front Panel Features](#) on page 6).
10. If applicable, mount the MTPs (see [Mounting](#) on page 19).

## Front Panel Features

See figure 2 to identify the front panel features on the transmitter and receiver.

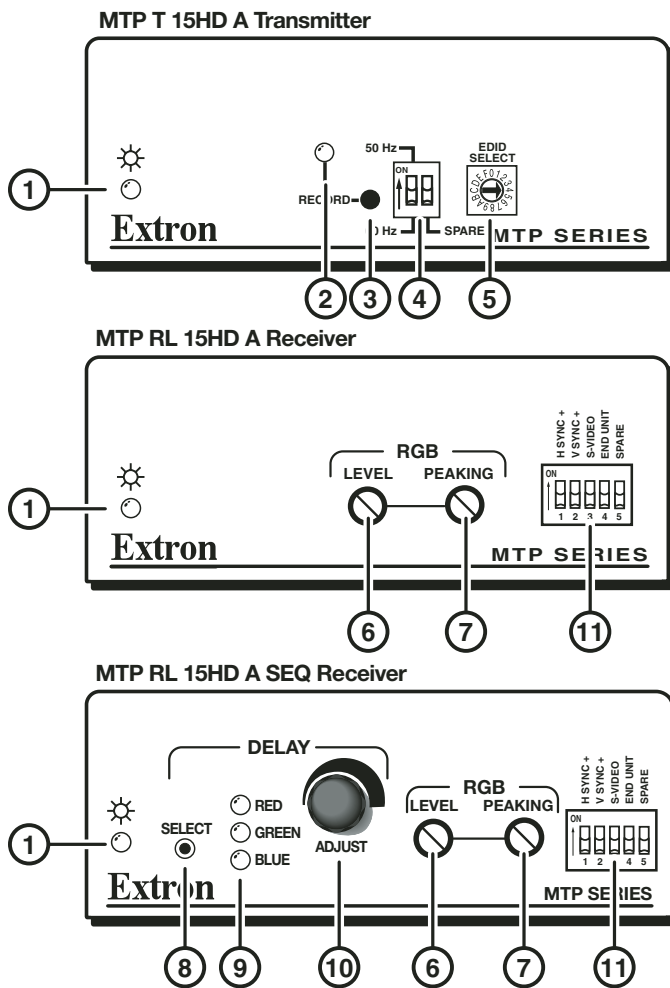

**Figure 2. MTP 15HD Front Panels**

- ① **Power LED** — The LED indicator lights when the unit is receiving power.
- ② **Record LED** — The LED indicator flashes red during the EDID recording process to indicate a new EDID being written to memory. The LED returns to a solid green after the write completes.
- ③ **Record button** — The recessed record button is used to initiate recording of the EDID of a display device (connected to the loop-out) to user-programmable memory position 0 on the rotary switch (⑤).
- ④ **Vertical frequency DIP switch** — The first DIP switch selects the vertical frequency for the pre-programmed EDID. When switched to OFF (default position), the EDID selected by the rotary positions 1 through E are based on 60 Hz. When switched to ON, they are based on 50 Hz. The second DIP switch, marked SPARE, is not used.

**NOTE:** When the EDID select rotary switch (⑤) is in position 0 or F, the setting of the first DIP switch is not applicable because the user-recorded or attached display EDID is being used.

- ⑤ **EDID select rotary switch** — The rotary switch is used to select specific pre-programmed or user-recorded EDID settings. Position 0 of this 16 position rotary switch is used to select the user recorded EDID. Position F passes the EDID from the display connected to the loop-out back to the input. Positions 1 through E select pre-programmed EDID resolutions.

**NOTE:** The refresh rate of the pre-programmed EDID resolutions is selected using the first DIP switch (④).

- ⑥ **Level control** — The level control alters the video output voltage to affect the brightness of the displayed image. Adjust the knob while viewing the displayed image to set the level that provides the best picture quality.

**NOTE:** For best results when using an RL receiver, connect a load to the buffered output on the receiver before adjusting the level.

- ⑦ **Peaking control** — Peaking affects the sharpness of a picture. Increased peaking can compensate for mid and high frequency detail loss from low bandwidth system components or capacitance in long cables. The minimum setting (at the counterclockwise limit) provides no peaking. The maximum setting (at the clockwise limit) provides 100% peaking. Adjust this control to obtain the optimum picture sharpness.

- ⑧ **Select button (SEQ model only)** — This recessed button selects the Red, Green, or Blue video signal to adjust and resets all three video signals to a skew delay of zero nanoseconds. Use a small screwdriver to press and release this button to cycle among selecting the Red, Green, or Blue video signal to adjust. The selected signal is indicated by the Red, Green, and Blue LEDs (⑨).

**NOTE:** The SEQ receiver automatically saves the setting for the video signal that is being deselected when you push this button or when the selection times out after 10 seconds.

Press and hold this button for approximately 3 seconds to set the skew delay for Red, Green, and Blue to zero. The Red, Green, and Blue LEDs (⑨) all turn off. Release the button.

- ⑨ **Red, Green, and Blue LEDs (SEQ model only)** — These LEDs indicate the video signal that is selected by the Select button (⑧) for skew adjustment using the Delay control (⑩). The LED of the selected color flashes when skew compensation for the selected video signal has reached the minimum or maximum limit.

- ⑩ **Delay (skew adjustment) control (SEQ model only)** — This control delays the selected Red, Green, or Blue video signal by up to 62 nanoseconds. The delay is applied in incremental, 2-nanosecond steps. Rotate the control counterclockwise to reduce the delay or clockwise to increase the delay.

**NOTES:**

- The control turns smoothly; it does not have mechanical steps or high and low limit stops.
- Watch the displayed image to observe the steps of delay.
- The selected Red, Green, or Blue LED (⑨) flashes to indicate that the control has reached the minimum (counterclockwise rotation) or maximum (clockwise rotation) limit.

⑪ **DIP switches (RL receivers only)** — A 5-pole DIP switch is used to configure the features of the MTP receivers.

- **Horizontal sync (H Sync +) switch** — Set this switch On (up) for positive horizontal sync or Off (down) for negative sync.
- **Vertical sync (V Sync +) switch** — Set this switch On (up) for positive vertical sync or Off (down) for negative sync.

**NOTE:** Most devices use negative sync for H Sync and V Sync.

- **S-Video switch** — This switch is used to set which pins of the 15-pin HD connector S-video is output on.
  - Set this switch On (up) to output chroma on pin 3 and luma on pin 2.
  - Set this switch Off (down) to output chroma on pin 1 and luma on pin 2.
- **End Unit switch** — Set this switch On (up) if either of the following is true:
  - The receiver being configured is the only receiver connected to the transmitter.
  - The receiver being configured is the last receiver in a daisy-chained system.

Set the End Unit switch Off (down) on the receiver being configured if there are one or more receivers connected to the Buffered Output RJ-45 connector (see figure 6, ③).

## Transmitter Rear Panel Features

Figure 3 shows an MTP T 15HD A transmitter, which has all of the connectors and other features that are on either transmitter in the MTP 15HD A series.

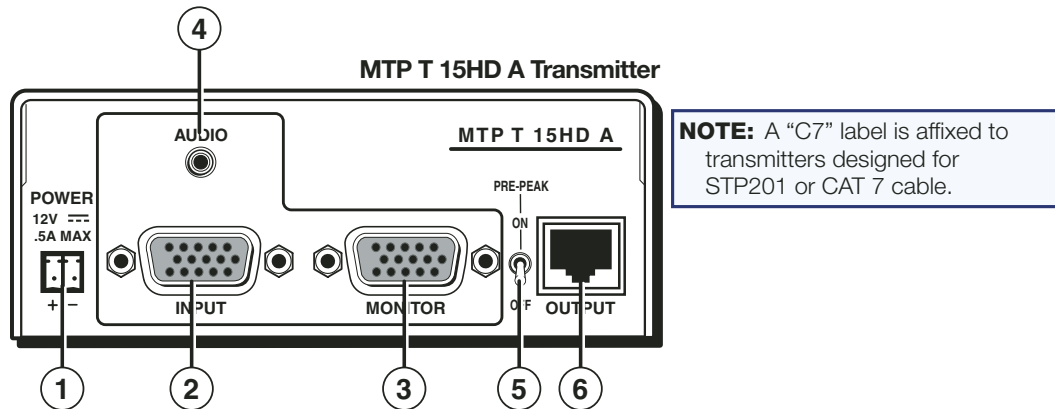

**Figure 3. Transmitter Rear Panel**

- ① **Power connector** — Plug the included external 12 VDC power supply into this 2-pole captive screw connector (see **Power Supply Wiring** on page 12 to wire the connector).

### NOTES:

- The length of the exposed wires in the stripping process is critical. The ideal length is 3/16 inches (5 mm). If the exposed section is longer, the exposed wires may touch, causing a short circuit between them. If it is shorter, the wires can be easily pulled out, even if tightly fastened by the captive screws.
- Do not tin the wires. Tinned wire does not hold its shape and can become loose over time.

- ② **Input video connector** — Connect a computer video source to this 15-pin HD connector for high resolution video input (see figure 4).

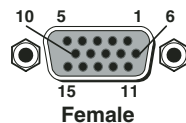

**Figure 4. 15-pin HD Connector**

### NOTES:

- Input only sync signals (no video signals) on the sync pins (13 and 14).
- For component video, use the R (R-Y) and R return pins (pins 1 and 6), G (Y) and G return pins (pins 2 and 7), and B (B-Y) and B return pins (pins 3 and 8). For S-video, use the R, R return (C-chroma), G, and G return (Y-luma) pins.
- For composite video, use the G pin and the associated return pin. For additional genlocked video signals, use the R, B, and associated return pins.

- ③ **Monitor connector** — Connect a video monitor to this 15-pin HD connector for buffered, high resolution video loop-through.

- ④ **Audio input connector** — Plug a 3.5 mm stereo audio plug into this connector for unbalanced audio input. Wire the plug as shown in figure 5. The stereo audio input is summed and output on the twisted pair cable as mono audio.

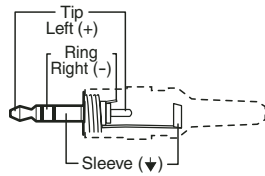

**Figure 5. 3.5 mm Stereo Audio Plug**

- ⑤ **Pre-Peak switch** — The Pre-Peak switch alters the twisted pair signal output to correct for long cable runs (see the [table](#) on page 4 for suggested switch settings based on the transmitted video format and transmission distance).
- ⑥ **Output connector** — Connect one end of a twisted pair cable to this RJ-45 female connector on the transmitter. Connect the free end of the same twisted pair cable to the RJ-45 female connector on the receiver (see [Twisted Pair Cable Termination](#) on page 14 to wire the RJ-45 connectors).

**ATTENTION: Potential damage to property.**

Do not connect these devices to a computer data or telecommunications network.

## Receiver Rear Panel Features

Figure 6 shows an MTP RL 15HD A receiver, which has all of the connectors and other features that are on either receiver in the MTP 15HD A series.

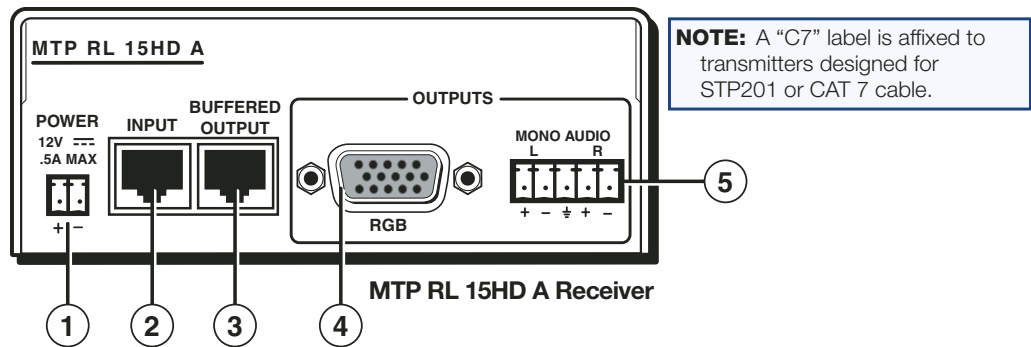

**Figure 6. Receiver Rear Panel**

- ① **Power connector** — Plug the included external 12 VDC power supply into this 2-pole captive screw connector (see **Power Supply Wiring** on page 12 to wire the connector).
- ② **Input connector** — Connect one end of the twisted pair cable from the transmitter or from the buffered output connector of an RL receiver to this RJ-45 female connector.
- ③ **Buffered output connector** — Connect one end of a twisted pair cable to this female RJ-45 connector. Connect the free end of the same twisted pair cable from the receiver to the Input RJ-45 female connector on another receiver (see **Twisted Pair Cable Termination** on page 14 to wire the RJ-45 connectors).
- ④ **Output video connector** — Connect a projector or other high resolution video device to this 15-pin HD connector.
- ⑤ **Mono audio output connector** — Insert a 3.5 mm, 5-pole captive screw audio connector into this connector for two mono audio outputs. Wire the connector as shown in figure 7. Use the supplied tie-wrap to strap the audio cable to the extended tail of the connector.

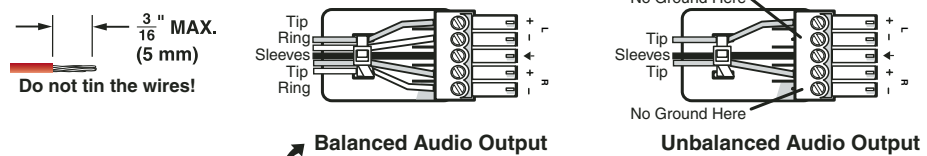

**ATTENTION: Potential damage to property.**  
 For unbalanced audio, connect the sleeve(s) to the ground contact.  
**DO NOT** connect the sleeve(s) to the negative (-) contacts.

**Figure 7. Captive Screw Audio Connector Wiring**

**NOTE:** The length of the exposed wires in the stripping process is critical. The ideal length is 3/16 inches (5 mm). If the exposed section is longer, the exposed wires may touch, causing a short circuit between them. If it is shorter, the wires can be easily pulled out, even if tightly fastened by the captive screws.



## Power Supply Wiring and Grounding

Figure 8 shows how to wire and ground the connector.

### ATTENTION:

- **Potential damage to property.**  
Power supply voltage polarity is critical. Incorrect voltage polarity can damage the power supply and the transmitter or receiver. Identify the power cord negative lead by the ridges on the side of the cord.
- To verify the polarity before connection, plug in the power supply with no load and check the output with a voltmeter.
- The length of the exposed (stripped) copper wires is important. The ideal length is 3/16 inches (5 mm). Longer bare wires can short together. Shorter wires are not as secure in the connector and could be pulled out.

Extron twisted pair products can be adversely affected by electrostatic discharge (ESD) if they are not grounded correctly. To prevent malfunctions or product damage, an installer can correctly ground an Extron twisted pair product by following the diagram in figure 8.

Ground the power port by inserting one end of the grounding wire to the negative or ground pin on the power input connector.

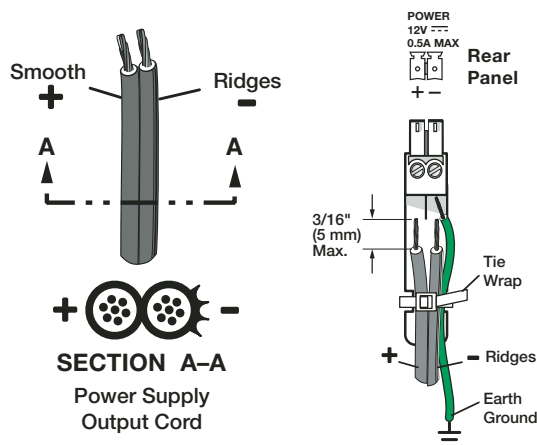

**Figure 8. Power Connector Wiring and Grounding**

### WARNING: Failure to follow these instructions may result in serious injury.

The two power cord wires must be kept separate while the power supply is plugged in. Disconnect the power before wiring.

### NOTES:

- Your transmitter/receiver pair may have shipped with a blue captive screw connector. This blue connector can be plugged into either a blue or an orange power receptacle. The blue connector does not have the extended tail or the included tie-wrap.
- Do not tin the power supply leads before installing in the direct insertion connector. Tinned wires are not as secure in the connectors and could be pulled out of the connector.

**ATTENTION:**

- **Potential damage to property.**

This product is intended to be supplied by a Listed Power Unit marked "Class 2" or "LPS", rated 12 VDC, maximum 1.0 A. Always use a power supply supplied or specified by Extron. Use of an unauthorized power supply voids all regulatory compliance certification and may cause damage to the supply and the end product.

- The installation must always be in accordance with the applicable provisions of National Electrical Code ANSI/NFPA 70, article 75, and the Canadian Electrical Code part 1, section 16. The power supply shall not be permanently fixed to building structure or similar structure.
- Unless otherwise stated, the AC/DC adapters are not suitable for use in air handling spaces or in wall cavities. The power supply is to be located within the same vicinity as the Extron AV processing equipment in an ordinary location, Pollution Degree 2, secured to the equipment rack within the dedicated closet, podium, or desk.

As an alternative, an Extron PS 124 Universal 12 VDC Power Supply (part number **60-1022-01**) can power multiple MTPs or other Extron 12 VDC devices using only one AC power connector.

## Twisted Pair Cable Termination

Figure 9 details the recommended termination of twisted pair cables with RJ-45 connectors in accordance with the TIA/EIA T568A or TIA/EIA T568B wiring standards. You can use either standard with CAT 5, 5e, 6, 7, and STP201 cable, but ensure that you **use the same standard on both ends of the cable**.

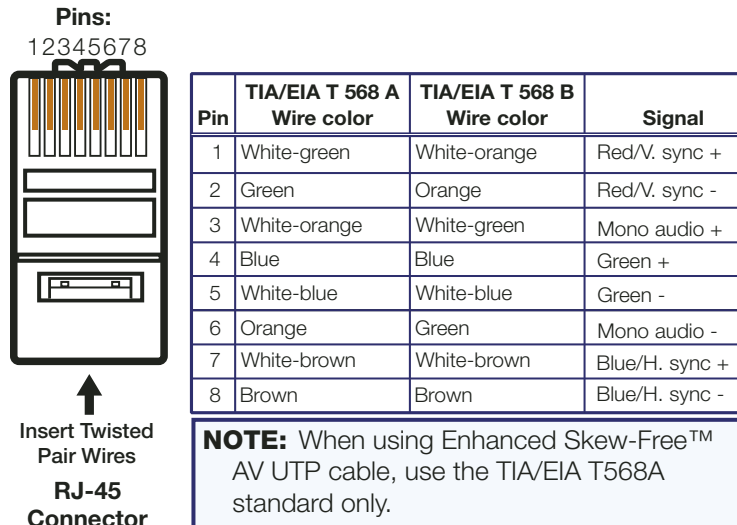

**Figure 9. Twisted Pair Cable Termination Diagram**

### NOTES:

- RJ-45 termination with CAT 5, 5e, or 6 cable must comply with the TIA/EIA T568A or TIA/EIA T568B wiring standards for all connections.
- RJ-45 termination with Skew-Free AV UTP cable must comply with TIA/EIA T568A only.
- For proper grounding of **shielded twisted pair cable**, ensure the shield around each wire pair are all tied to the RJ-45 connectors on both ends, in accordance with the connector specifications provided by the manufacturer.
- Extron Enhanced Skew-Free AV cable is not recommended for Ethernet/LAN applications. This cable is specially designed for compatibility with Extron Twisted Pair products that are wired using the TIA/EIA T568A standard.
- The green, brown, and blue wire pairs of this cable have virtually identical lengths and should be used to transmit the RGB signals.
- The orange wire pair of this cable has a different length and **should not** be used to transmit the RGB signals.

## Skew Delay Compensation

CAT 5, 5e, 6, 7, and STP201 cable can lead to registration errors between the Red, Green, and Blue video signals. Pair skew can be measured with test equipment or identified by viewing a crosshatch test pattern with a critical eye to determine if either the Red, Green, or Blue video image leads (appears to the left of) the other two video images.

**NOTE:** Unless the twisted pair cable is changed, the skew adjustment should need to be made only once, during installation.

### SEQ Receiver Skew Compensation

The SEQ receiver has built-in skew compensation capabilities. Adjust the equalization as follows:

1. **Zero the skew delay** for Red, Green, and Blue as follows:
  - a. Use a small screwdriver to press and **hold** the Select button for 3 seconds. The Red, Green, and Blue LEDs all go out.
  - b. Release the Select button.
2. Use UTP cable test equipment or examine the displayed video image with a critical eye to **determine which video signal** — Red, Green, or Blue — **is most shifted to the left.**

**NOTE:** A crosshatch test pattern or a black background with vertical white lines is ideal for determining skew.

3. Adjust the leftmost video signal as follows:

**NOTE:** The SEQ receiver cannot shift the rightmost video image to the left.

- a. Use a small screwdriver to press and release the Select button until the LED lights for the left-shifted color — Red, Green, or Blue.
  - b. **Slowly** rotate the Delay control clockwise while monitoring the display. Observe that the leftmost color shifts rightward one step at a time. Continue to rotate the control until that color is properly converged.
- NOTE:** A 2-nanosecond adjustment is very fine. Up to 10 nanoseconds of delay may be necessary before you detect a change in the display.
- c. Use a small screwdriver to press the Select button one more time to save the most recent adjustment or allow the 10-second time-out to elapse.
4. If the remaining colors are left shifted, repeat steps 2 and 3.

### Non-SEQ Receiver Skew Compensation

Try using the following methods to minimize or eliminate pair skew:

- Switch to Extron Enhanced Skew-Free AV UTP cable.
- Add a skew compensation cable equal to the length of pair skew to the output of the receiver.
- Install an SEQ 100 15HD Skew Equalizer to the video output of the receiver and adjust the skew for the leading video image.

## EDID Configuration

The MTP 15HD A transmitter can either record EDID from a display device, or a pre-programmed EDID can be selected using the rotary and DIP switches.

### Recording a Display EDID

1. Turn the rotary switch to position 0.

**NOTE:** The vertical frequency DIP switch has no effect in this mode.

2. Connect the display device to the local monitor output connector.

**NOTE:** The MTP 15HD transmitter should be supplying the necessary 5 VDC to power on the display. However, to ensure that EDID is being transmitted, power on the display.

3. When ready to record to memory, press and release the recessed record button (see ③ on page 6) to begin the recording process. The Record LED (see ② on page 6) will flash red rapidly during recording, then return to solid green after recording is completed. At this time, the display can be disconnected. Connect the source device to the input connector.
4. Power on or restart the source device if necessary.

### Using a Pre-Programmed or User-Recorded EDID

1. If you have not already done so, connect the source device to the MTP 15HD transmitter. Do not power on the source device at this time.
2. Set the front panel DIP switch (see ④ on page 6) to the required frequency (50 or 60 Hz).
3. Set the rotary dial (see ⑤ on page 7) to the required position (see table below). Positions 1 through E are factory installed. Position 0 is for user-recorded EDID information. Position F passes the EDID from the display connected to the loop-out directly back to the input.

Rotary Switch Position	Resolution
0	User-recorded EDID
1	800x600
2	1024x768 (default)
3	1280x720
4	1280x768
5	1280x800
6	1280x1024
7	1360x768
8	1366x768
9	1400x1050
A	1400x900
B	1600x1200
C	1680x1050
D	1920x1080
E	1920x1200
F	Local monitor pass-through

# Reference Information

This section provides information about:

- **Part Numbers, Optional Accessories, Cables, and Connectors**

## Part Numbers, Optional Accessories, Cables, and Connectors

### Part Numbers

<b>MTP Transmitter and Receivers</b>	<b>Part Number</b>
MTP T 15HD A transmitter	60-1282-01
<i>or</i> MTP RL 15HD A receiver	60-690-01
<i>or</i> MTP RL 15HD A SEQ receiver	60-690-02

<b>Included Parts</b>	<b>Part Number</b>
12 VDC 1.0 A desktop power supply	28-071-57LF
IEC power cord	27-044-01
5-pole captive screw connector	10-703-12LF
(4) Rubber feet (not attached)	
Tweezer	
Setup Guide — MTP 15HD A Series	

### Optional Accessories

<b>Description</b>	<b>Part Number</b>
PS 124 multiple output 12 volt DC power supply	60-1022-01
MBB 100 (1/8 and 1/4 back of rack mounting kit)	70-367-01
MBU 123 under desk mounting kit	70-212-01
PMK 100 (1/4 rack width pole mount kit)	70-217-01
RSF 123 (3.5 inches deep, 1U rack shelf kit)	60-190-20
RSB 123 (3.5 inches deep, 1U basic rack shelf)	60-604-21
RSU 126 (6 inches deep, 1U rack shelf kit)	60-190-10
RSB 126 (6 inches deep, 1U basic rack shelf)	60-604-11
RSU 129 (9.5 inches deep, 1U rack shelf kit)	60-190-01
RSB 129 (9.5 inches deep, 1U basic rack shelf)	60-604-02

## Cables

**NOTE:** Extron Enhanced Skew-Free AV UTP cables are not recommended for Ethernet or LAN applications.

Description	Part Number
VGA connector cable	26-238-xx
SYM BNC Female Mini High Resolution cable	21-251-xx
Extron Enhanced Skew-Free AV UTP cable (cut, various lengths)	26-569-xx
Extron Enhanced Skew-Free AV UTP cable 1000' (bulk) (Non-Plenum)	22-141-03
Extron Enhanced Skew-Free AV UTP cable 1000' (bulk) (Plenum)	22-142-03
STP201 Shielded Digital Twisted Pair cable 1000' (bulk) (Non-Plenum)	22-214-03
STP201P Shielded Digital Twisted Pair cable 1000' (bulk) (Plenum)	22-215-03

## Connectors

RJ-45 Connectors	Part Number
CAT 6 jack (Black), quantity 10	100-476-01
CAT 6 jack (Red), quantity 10	100-477-01
CAT 6 jack (Blue), quantity 10	100-478-01
CAT 6 jack (Orange), quantity 10	100-479-01
CAT 6 jack (Gray), quantity 10	100-480-01
CAT 6 jack (White), quantity 10	100-481-01
CAT 6 jack (Ivory), quantity 10	100-482-01
Shielded RJ-45 for STP201 cable	101-005-01

# Mounting

This section outlines the various mounting options available for the MTP 15HD A Series transmitters and receivers:

- **Tabletop Placement**
- **Under-Desk Mounting**
- **Rack Mounting**
- **Projector Mounting**

## Tabletop Placement

Attach the four provided rubber feet to the bottom of the unit and place it in any convenient location.

## Under Desk and Furniture Mounting

Mount the unit under a desk or podium using the optional Extron MBU 123 under desk mounting kit (part number **70-212-01**). To mount the unit, follow the instructions provided with the MBU 123 kit.

## Rack Mounting

### UL Guidelines for Rack Mounting

The following Underwriters Laboratories (UL) guidelines are relevant to the safe installation of these products in a rack:

- 1. Elevated operating ambient temperature** — If the unit is installed in a closed or multi-unit rack assembly, the operating ambient temperature of the rack environment may be greater than room ambient temperature. Therefore, install the equipment in an environment compatible with the maximum ambient temperature (TMA = +122 °F, +50 °C) specified by Extron.
- 2. Reduced air flow** — Install the equipment in the rack so that safe operation and adequate air flow is provided to the unit.
- 3. Mechanical loading** — Mount the equipment in the rack so that a hazardous condition is not achieved due to uneven mechanical loading.
- 4. Circuit overloading** — Connect the equipment to the supply circuit and consider the effect that circuit overloading might have on overcurrent protection and supply wiring. Consider the equipment nameplate ratings when addressing this concern.
- 5. Reliable earthing (grounding)** — Maintain reliable grounding of rack-mounted equipment. Pay particular attention to supply connections other than direct connections to the branch circuit (such as the use of power strips).



## Rack Mounting Procedure

These units can be mounted on any of these optional rack systems, including:

- **RSF 123: 3.5 inch deep, 1U rack shelf kit (part number 60-190-20)**
- **RSB 123: 3.5 inch deep, 1U basic rack shelf (part number 60-604-21)**
- **RSU 126: 6 inch deep, 1U rack shelf kit (part number 60-190-10)**
- **RSB 126: 6 inch deep, 1U basic rack shelf (part number 60-604-11)**
- **RSU 129: 9.5 inch deep, 1U rack shelf kit (part number 60-190-01)**
- **RSB 129: 9.5 inch deep, 1U basic rack shelf (part number 60-604-02)**

To mount the unit on a rack shelf, follow the instructions provided with the shelf accessories.

## Back of the Rack Mounting Procedure

The MTP can be mounted to the rear of a rack using the Extron MBB 100 1/8 and 1/4 Back of Rack Mounting Kit (part number **70-367-01**). The kit allows the product to be vertically mounted to the front or rear rack supports and facing either towards the front or the rear of the rack.

To mount the unit, follow the instructions provided with the MBB 100 kit.

## Projector Mounting

Mount the unit onto a projector using the optional Extron PMK 100 1/4 rack width pole mount kit (part number **70-217-01**). To mount the unit, follow the instructions provided with the PMK 100 kit.

## Extron Warranty

Extron Electronics warrants this product against defects in materials and workmanship for a period of three years from the date of purchase. In the event of malfunction during the warranty period attributable directly to faulty workmanship and/or materials, Extron Electronics will, at its option, repair or replace said products or components, to whatever extent it shall deem necessary to restore said product to proper operating condition, provided that it is returned within the warranty period, with proof of purchase and description of malfunction to:

**USA, Canada, South America,  
and Central America:**

Extron Electronics  
1230 South Lewis Street  
Anaheim, CA 92805  
U.S.A.

**Japan:**

Extron Electronics, Japan  
Kyodo Building, 16 Ichibancho  
Chiyoda-ku, Tokyo 102-0082  
Japan

**Europe and Africa:**

Extron Europe  
Hanzeboulevard 10  
3825 PH Amersfoort  
The Netherlands

**China:**

Extron China  
686 Ronghua Road  
Songjiang District  
Shanghai 201611  
China

**Asia:**

Extron Asia Pte Ltd  
135 Joo Seng Road, #04-01  
PM Industrial Bldg.  
Singapore 368363  
Singapore

**Middle East:**

Extron Middle East  
Dubai Airport Free Zone  
F12, PO Box 293666  
United Arab Emirates, Dubai

This Limited Warranty does not apply if the fault has been caused by misuse, improper handling care, electrical or mechanical abuse, abnormal operating conditions, or if modifications were made to the product that were not authorized by Extron.

**NOTE:** If a product is defective, please call Extron and ask for an Application Engineer to receive an RA (Return Authorization) number. This will begin the repair process.

**USA:** 714.491.1500 or 800.633.9876

**Asia:** 65.6383.4400

**Europe:** 31.33.453.4040

**Japan:** 81.3.3511.7655

Units must be returned insured, with shipping charges prepaid. If not insured, you assume the risk of loss or damage during shipment. Returned units must include the serial number and a description of the problem, as well as the name of the person to contact in case there are any questions.

Extron Electronics makes no further warranties either expressed or implied with respect to the product and its quality, performance, merchantability, or fitness for any particular use. In no event will Extron Electronics be liable for direct, indirect, or consequential damages resulting from any defect in this product even if Extron Electronics has been advised of such damage.

Please note that laws vary from state to state and country to country, and that some provisions of this warranty may not apply to you.

<b>Extron Headquarters</b> +1.800.633.9876 (Inside USA/Canada Only) Extron USA - West +1.714.491.1500 +1.714.491.1517 FAX	<b>Extron Europe</b> +800.3987.6673 (Inside Europe Only) Extron USA - East +1.919.850.1000 +1.919.850.1001 FAX	<b>Extron Asia</b> +800.7339.8766 (Inside Asia Only) +65.6383.4400 +65.6383.4664 FAX	<b>Extron Japan</b> +81.3.3511.7655 +81.3.3511.7656 FAX	<b>Extron China</b> +4000.398766 Inside China Only +86.21.3760.1568 +86.21.3760.1566 FAX	<b>Extron Middle East</b> +971.4.2991800 +971.4.2991880 FAX	<b>Extron Korea</b> +82.2.3444.1571 +82.2.3444.1575 FAX	<b>Extron India</b> 1800.3070.3777 Inside India Only +91.80.3055.3777 +91.80.3055.3737 FAX
---	---	--	---	--	---	---	--